

SiRFstarII™ GPS Single Chip

A Low Power GPS Single-Chip with ROM Based Software

SiRF Chips and Software

ARCHITECTURE HIGHLIGHTS

Mainstream GPS Performance Leader

- Signal acquisition using 1920 time/frequency search channels
- SBAS (WAAS and EGNOS), and DGPS support
- Multipath-mitigation hardware
- Cold Start under 45 seconds
- Architecture supports user task integration (GSC2x only)
- Compatible with SiRFLoc and SiRFXTrac

Low Power

- Under 100 mW at full power
- TricklePower™ mode reduces power to under 35 mW
- Adaptive TricklePower intelligently switches between full and TricklePower.
- Push to fix reduces power by as much as 98%

Maximizes GPS Position Availability

- Superior urban canyon performance
- FoliageLock™ for weak signal tracking

FAMILY HIGHLIGHTS

GSC2x and GSC2xr Single Chip

- GSC2x uses ROM or Flash based Software
- GSC2xr is limited to ROM based Software
- Digital and RF in a single 7 x 10mm BGA package
- ARM7TDMI Microprocessor throughput measured at up to 40 MIPS (GSC2x Only)
- 8k of cache for improved throughput
- On-chip 1Mb SRAM for GPS navigation
- Integrated high-precision Real-Time Clock with failure detection circuitry
- Extensive GPS receiver peripherals 2 UARTS, high speed serial bus, battery backed SRAM, >40 GPIO

GSWx2 Modular Software

- ROM software supports popular protocol and LED outputs with four user-selectable configurations
- Software in ROM or customize for use from Flash
- 95% CPU throughput available for user tasks
- Robust development environment

SiRFstarII ARCHITECTURE

The SiRFstarIIe/LP architecture set the standard for high volume GPS performance. This architecture is now available in a single chip package called the GSC2x. The GSC2x uses the SiRFstarIIe/LP's 1920 correlators and 12 channels for fast acquisitions and excellent tracking performance, but now offers a smaller form factor and lower power. Both the baseband and RF are combined into a single package along with software in ROM making for an extremely small receiver. Power consumption is reduced to under 35mW during tracking.

In addition, the RF section accepts seven different reference frequencies, making it possible to share oscillators and further reduce the size of the receiver. The ROM based software has been proven on millions of shipped chipsets. The chip comes in two versions, the GSC2x which provides access to extra CPU throughput for user tasks and the GSC2xr which uses ROM and the fixed configurations. The GSC2x also can be used with SiRFXTrac or SiRFLoc software.



SiRFstarII GSC2x BLOCK DIAGRAM

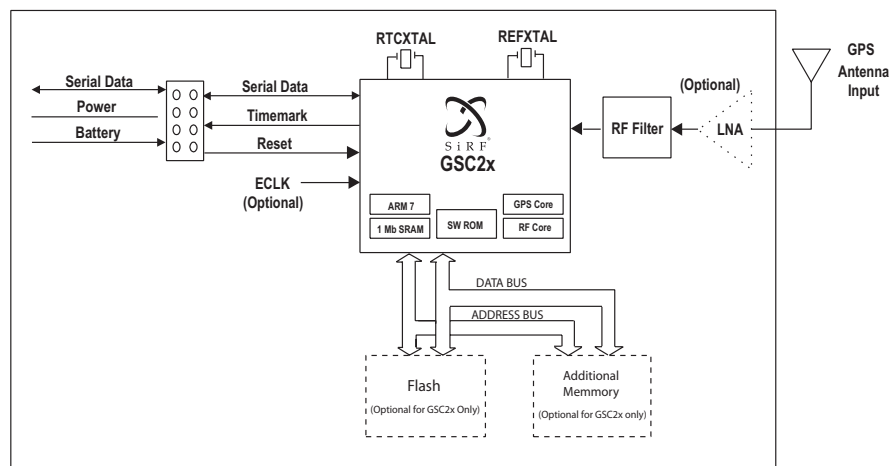

TECHNICAL SPECIFICATIONS

Position Accuracy	
Autonomous	<10m
WAAS	<5m
Receiver	
Tracking	L1, CA code
Channels	12
Max. Update Rate	10Hz
Sensitivity	-172dBW
Max. Altitude	<60,000 ft
Max. Velocity	<1,000 knots
Protocol Support	NMEA, SiRF Binary
Acquisition	
Reacquisition Time	100msec
SnapStart	<3sec
Hot Start	<8sec
Warm Start	<38sec
Cold Start	<45sec
Power	
Full Power	<100mW
TricklePower (1Hz)	<35mW (est)
Voltage	2.7-3.3V (5V I/O capable)
Processor	
Processor Type	ARM7TDMI
Processor Speeds	6MHz, 12.5MHz, 25MHz, 49MHz
Data Bus	16 Bit
Ports	>40 GPIO

Specifications above are for GSWx2

WORLDWIDE SALES OFFICES

SiRF California
+1 (408) 467-0410
SalesAmericas@sirf.com

SiRF United Kingdom
+44 1344 668390
SalesUK@sirf.com

SiRF Japan
+81 44829-2186
SalesJapan@sirf.com

SiRF France
+33 3 82 86 04 15
SalesFrance@sirf.com

SiRF Europe
+49 81 529932-90
SalesGermany@sirf.com

SiRF Taiwan
+886 2 2723 7853
SalesAsiaPacific@sirf.com

SiRF India
+91 120 251 0256
SalesIndia@sirf.com

APPLICATIONS

The SiRFstarIIe/LP has been used in many successful outdoor applications, from GPS handhelds, to personal navigators, and automatic vehicle location modules. The GSC2x with its low-power single chip package and integrated software makes the SiRFstarII architecture even more flexible. GPS centric applications such as GPS handhelds and Radar Locators can take advantage of the GSC2x's excess processing power to perform customer user tasks. Battery powered applications such as Bluetooth accessories will enjoy the low power consumption and low power modes that extend battery life. Applications not needing customization will benefit by the removal of Flash from the bill of material. Many devices can take advantage of the ROM based software, which supports popular protocols and LED outputs. The new form factor will enable GPS applications where size is critical such as location aware cameras, and watches.

CHIP ORDERING CONFIGURATION

AVAILABLE PACKAGES

Chip Name	Chip PN	Package
SiRFstarII GSC2x	GSC2x-7477	BGA, 7mm x 10mm
SiRFstarII GSC2x	GSC2x-7479	BGA, 7mm x 10mm Pb-Free
SiRFstarII GRF2xr	GSC2xr-7474	BGA, 7mm x 10mm (ROM Only)
SiRFstarII GRF2xr	GSC2xr-7475	BGA, 7mm x 10mm (ROM Only) Pb-Free

ADDITIONAL SOFTWARE OPTIONS

SiRFXtrac (High Sensitivity stand alone software)
SiRFLoc (High Sensitivity multimode software)

For more information, contact your SiRF representative, call our sales force on +1 (408) 467-0410, or visit us at www.sirf.com.

Mobile Compute



Consumer and marine

Automobile



Wireless